

Everything I believed about nuclear waste was wrong

I've feared it. I've protested it. Now I'm hugging it

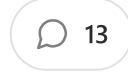

Zion Lights
Feb 9

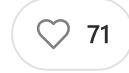

Visiting dry storage casks at Sizewell B in Suffolk, UK

For most of my life, I have been terrified of nuclear waste. I believed it was a green, gloopy, corrosive liquid as depicted in *The Simpsons*. I thought it was dumped in rivers, contaminated the environment with radiation and gave people cancer. I feared waste as if it was cancer.

Zion Lights is a reader-supported publication.
To receive new posts and support my work,

consider becoming a free or paid subscriber.

Type your email...	Subscribe
--------------------	-----------

I was 18 years old and I believed that nuclear energy was dangerous, the nuclear industry was evil, and renewables were the only way to save humankind.

I changed my mind about nuclear energy when I learned that it is essential for decarbonisation, that nuclear power stations have the **smallest land footprint** of all the energy sources per unit of electricity they produce, and that the energy they produce is **clean** and reliable. However, one thing continued to concern me: nuclear waste.

I had been told by countless friends and green organisations, of which I was an active member, that there were huge amounts of nuclear waste in the world, that it could not be disposed of safely, and that it was leaking into our precious environment. It was years before I realised that I had been misinformed, by people who were themselves misinformed.



Discover more from Zion Lights

Reporting on science, energy, and climate

Subscribe

Continue reading >

Sign in

radioactive they are. Low- and medium- level
tools, wiping cloths, and other disposable
particularly hazardous, but because of the
treated with rigorous caution - so much so that
recycled as scrap if their radiation levels are **a**
n the oil and gas industry.

or *spent*, nuclear reactor fuel. This fuel is in a
metal tubes called rods. A structured group of
ong: there is no scary green liquid. The waste

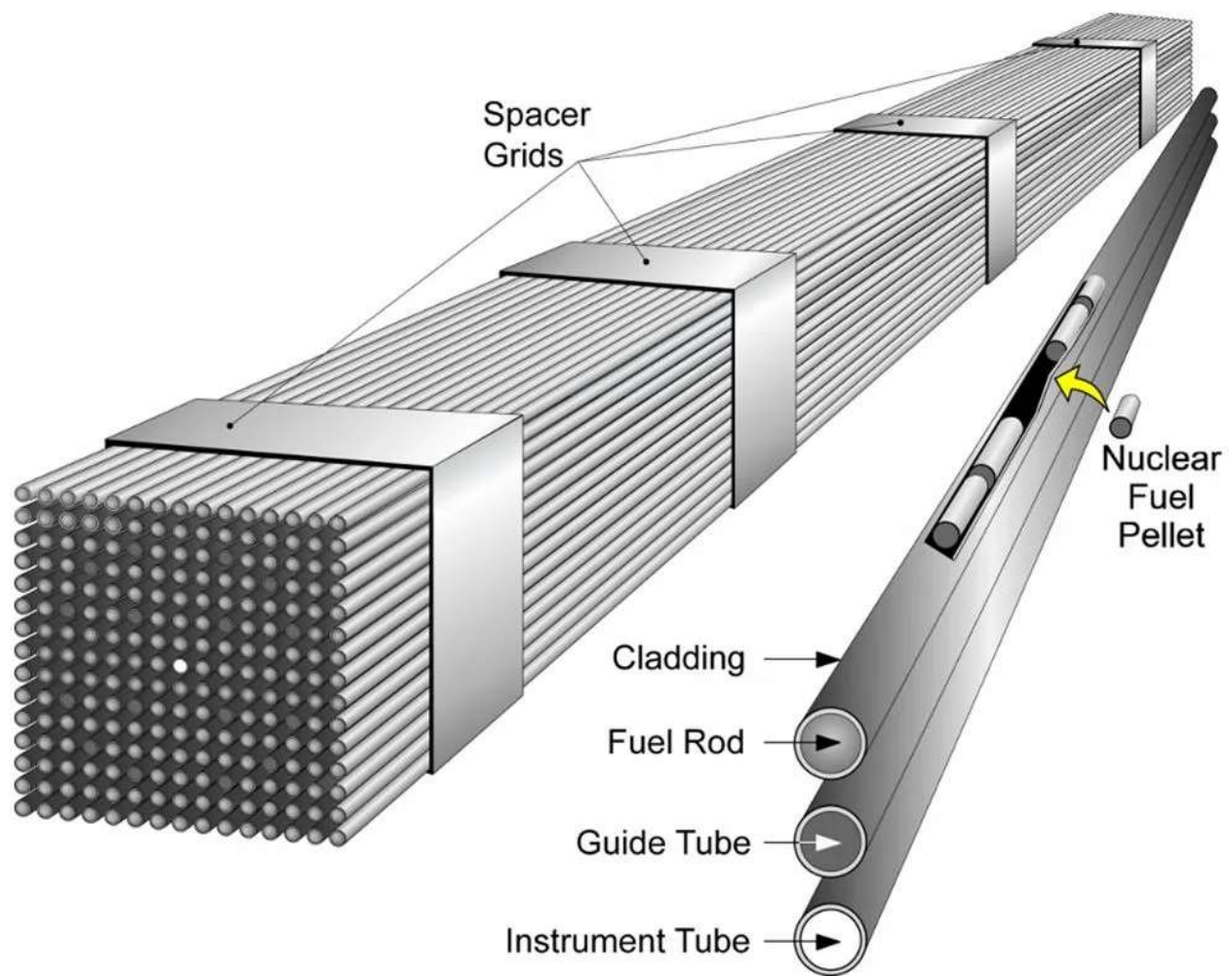

Nuclear fuel schematic (Image: U.S. Department of Energy)

What I'd been told about leaking waste was not to do with nuclear energy. The leaky vats I was afraid of were from weapons-related reactors, such as the **Hanford Nuclear Site** in Washington State, where the U.S. Department of Defense and the Department of Energy produced plutonium for use in the atomic weapon program. Some of these contaminants leaked into the land and water, including into the Columbia River.

I learned that I had been confusing waste from nuclear energy with waste from nuclear weapons.

How much waste is there?

I was also confused about how much nuclear waste there is in the world. It turns out that there isn't very much of it. All the high-level nuclear waste produced in the world would **fit in a single football field** to a height of approximately ten yards.

The amount of high-level waste produced during nuclear energy production is also small: a typical large reactor produces about 25-30 tonnes of used fuel per year. Worldwide, 97% of the waste produced by the nuclear power industry is classified as low- or medium-level waste. In France, where fuel is reprocessed, just 0.2% of all radioactive waste by volume is classified as high-level waste.

Cooling pools

When a fuel assembly is removed from a reactor because it can no longer provide useful power it is extremely hot, both thermally and radioactively. It is immediately transferred to a cooling pool where it is stored alongside other used fuel for two to ten years as it cools down and becomes less radioactive. After this, it can be moved to a dry storage cask.

What about the radiation?

After I realised how wrong I'd been about what nuclear waste is, I was determined to learn how it is managed. This required a lot more work as I had to understand how waste is managed by other industries and also from fossil fuels and renewable production, to give a fair comparison.

We live in an industrialised civilisation where waste is a by-product of our everyday lifestyles. Many of these wastes are hazardous, including lead, mercury, arsenic, cadmium, chromium, chlorine, hydrofluoric acid, cyanide, asbestos, dioxins, many other carcinogens, clinical wastes and various pathogens. They are, for the most part, managed carefully. But arguably, of all of them, nuclear waste is managed the most carefully.

I had this misconception about nuclear waste and radioactivity, where I believed that it would stay highly radioactive for many hundreds of thousands of years. I learned that unlike other industrial toxic wastes, the principal hazard associated with high-level waste - radioactivity - diminishes significantly with time. This is known as *radioactive decay*. The amount of time it takes for the radioactivity of radioactive material to decrease to half its original level is called the *radioactive half-life*.

The decay of heat and radioactivity over time means that after only forty years, the radioactivity of used fuel has decreased to about one-thousandth of the level at the point when it was unloaded. Less than 1% is radioactive for 10,000 years. This portion can be easily isolated and shielded to protect humans and wildlife.

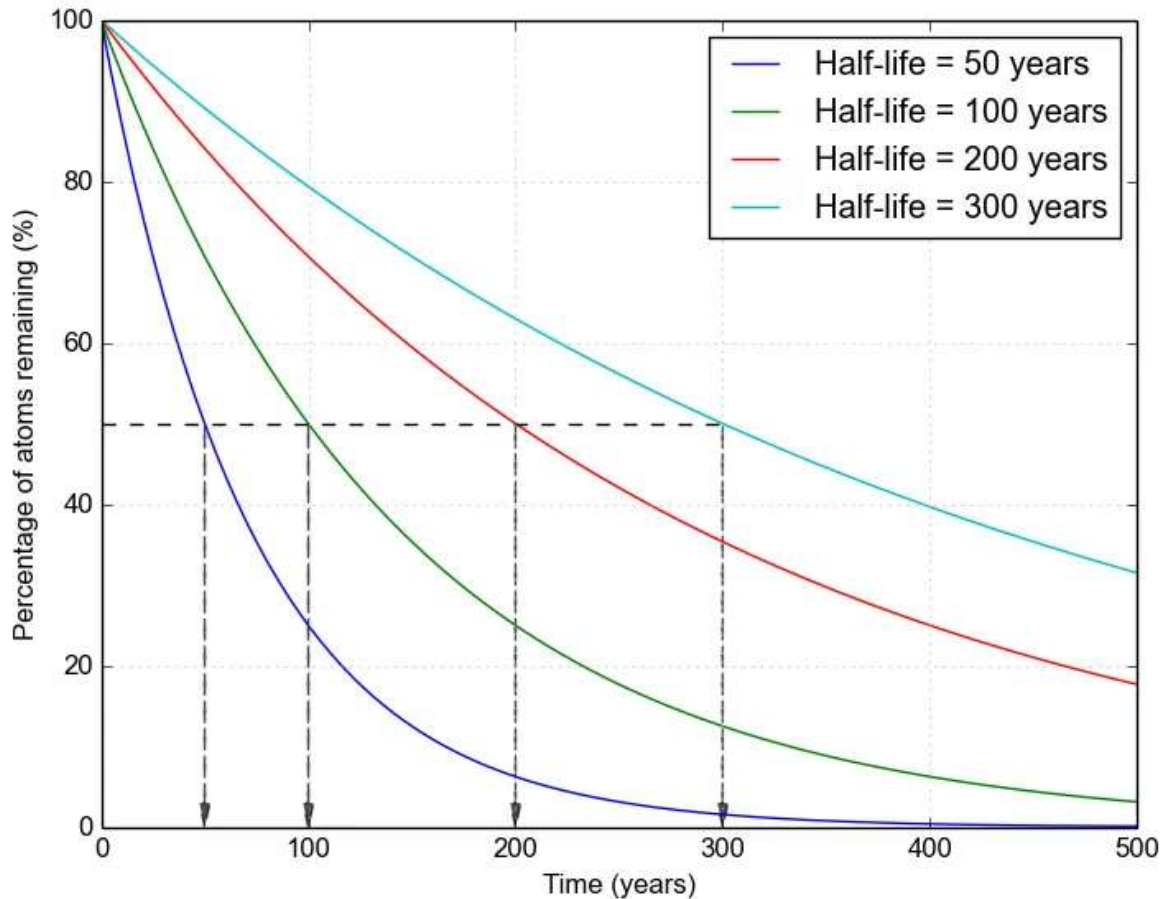

How is nuclear waste transported?

When spent fuel has to be transported, e.g. to reprocessing plants, it is carried in dry storage casks. These containers are extremely strong and have been rigorously tested by being dropped from heights, having [railway locomotives crash into them](#), and planes flown into them, as demonstrated by [this cask test](#) from 1978.

What is dry storage?

When the fuel assembly has cooled down, it is transferred to a stainless-steel and concrete dry storage cask. These are designed to contain fuel assemblies for around a century. The casks shield radiation, which means you can stand next to one and not be exposed to radiation from the waste inside. The casks are usually stored at the power station. I'm standing among dry storage casks in the photo at the top of this article.

Dry Storage of Spent Fuel

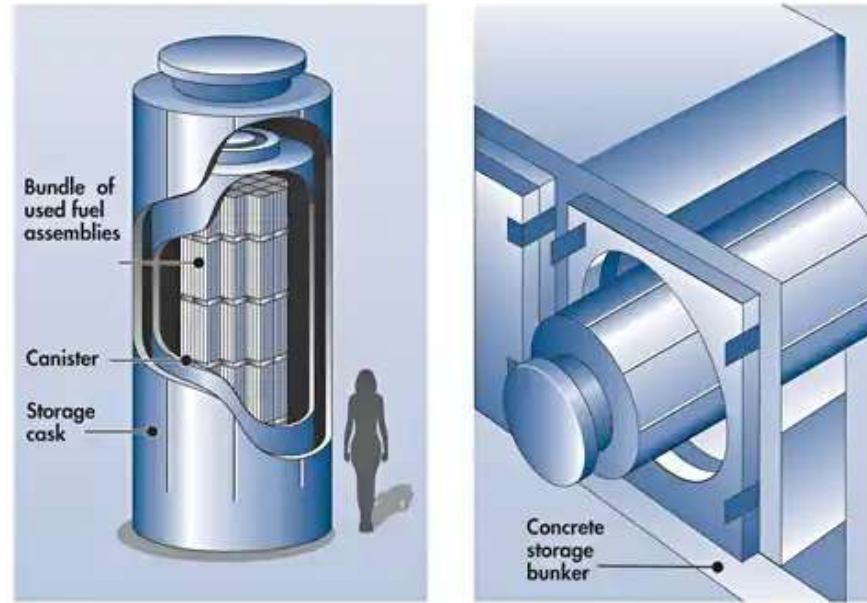

Reduce, reuse, reprocess

Fuel rods contain 90% of the potential energy from the uranium in them. In some countries, such as France, Japan, and Russia, used fuel is reprocessed to extract usable fuel to make new fuel assemblies. Through this method of recycling, up to 96% of the reusable material in spent fuel can be recovered.

France's national policy of recycling spent fuel has meant that it needs 17% less natural uranium to operate its plants than it would without recycling. There is currently enough energy in the nuclear waste in the United States to power the entire country for 100 years with clean energy.

It's a no-brainer to me, now, to say that we should go green and recycle our nuclear waste. Ultimately, it's only waste if you waste it.

Deep geological repositories

The international scientific consensus is that deep geological repositories are the most effective approach to permanently dispose of high-level radioactive waste. Deep geological repositories are already an accepted method of long-term disposal of waste containing arsenic, cyanide, mercury, and other toxic chemicals.

Finland has created the world's first deep geological repository 450 metres below ground level to bury high-level nuclear waste, and Sweden has just approved plans for their first underground

repository.

My Danish friend Johan sent me [this video](#) of his visit to Finland's new repository.

How does other waste compare?

If we want to compare like for like, we have to think about nuclear waste versus waste from other energy production industries.

As you read this, waste from fossil fuels is being stored in the Earth's atmosphere, and we breathe it in every day. Air pollution from fossil fuels causes **millions of deaths a year**.

When I was 24 I attended an anti-nuclear protest because of what we environmentalists believed was a silent killer: radiation. But radiation hasn't harmed anywhere near as many people as fossil fuels. I now realise that we live with real silent killers every day: air pollution from burning fossil fuels and the slow march of climate change.

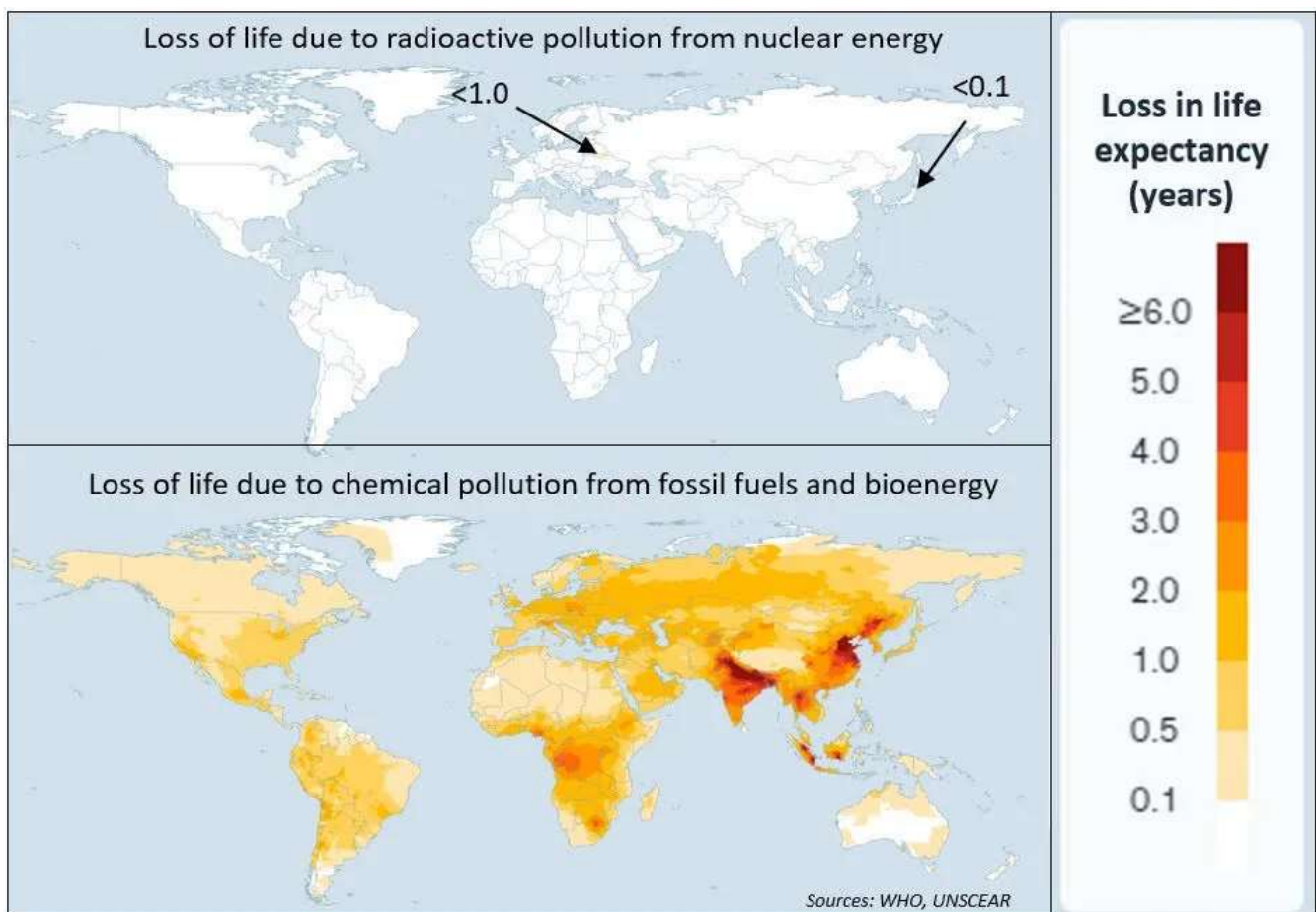

Waste from renewables is seldom recycled because it is difficult to do. I championed renewable technologies for years, so it came as a shock to me to learn that the solar panels I had been promoting as an environmental solution are rarely recycled. The **toxic waste they leave behind** usually ends up in landfill sites where it **leaches dangerous chemicals** into the ground, often in developing countries where it is dumped. I also learned that batteries cannot be recycled. And that wind turbine blades have **similar issues**. This isn't to say that we should abandon renewables altogether, but to illustrate that all energy generation carries an environmental cost, and no solution is perfect.

I was 29 and I was heartbroken. With the scaling of renewables, how were we going to wean off of fossil fuels and still meet our energy needs? It was time for me to rethink nuclear energy.

What about waste from mining?

All sources of energy and virtually everything that supports your daily life - your phone, the chair you're sitting on, the packaging your food arrived in, the table you ate it at - requires a degree of mining. The impressive thing about nuclear energy is that it is powered by uranium, which is an incredibly dense energy source, which means that we need very little uranium to create a lot of power, which is a good thing if, like me, you care about efficiency, recycling, and doing as little harm to the environment as possible.

Of all the energy sources, nuclear uses the least amount of materials.

Spatial and material requirements by energy source*

Bubble size represents each source's use of critical metal use**

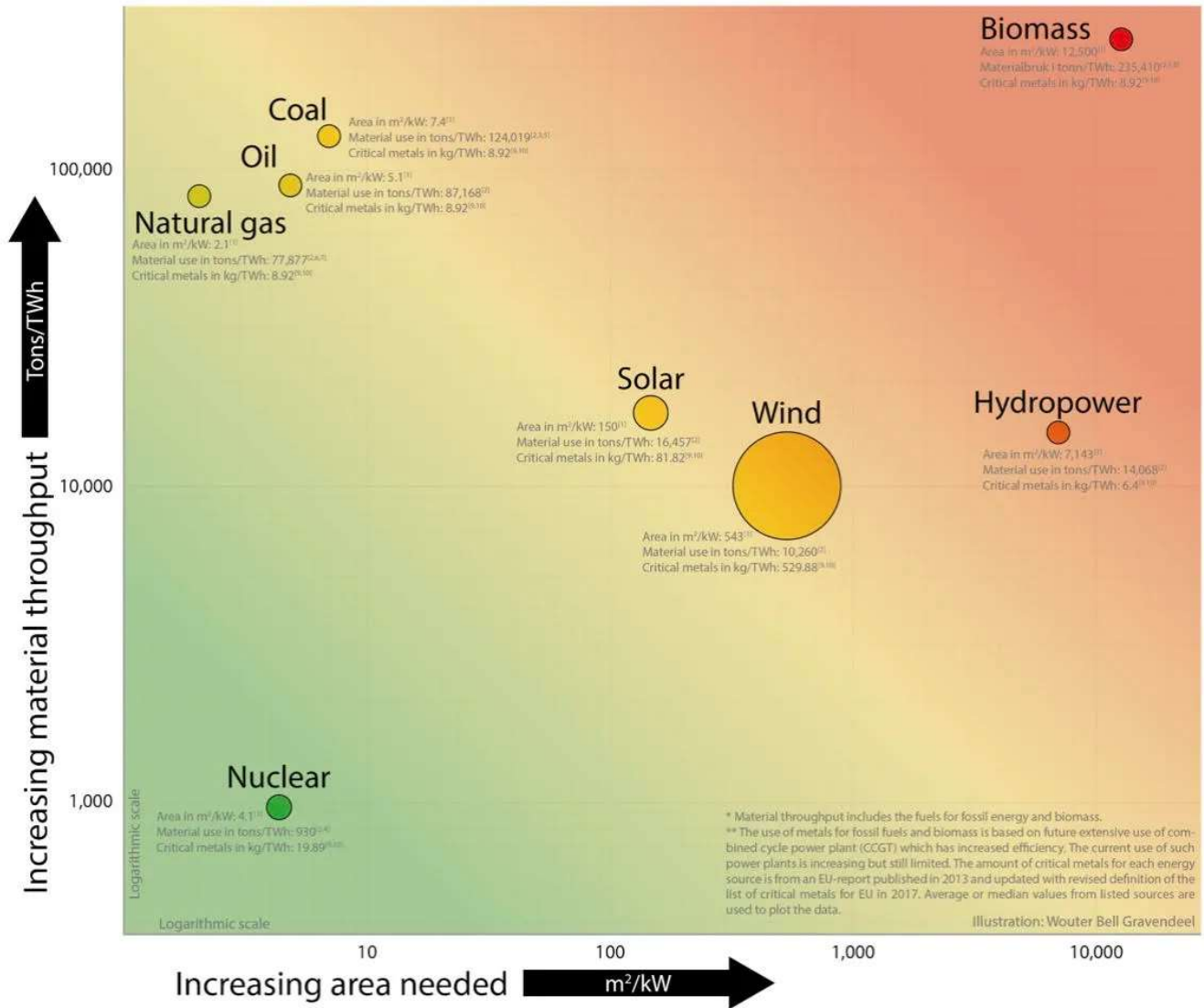

Sources:

- 1) van Zile, John, and Paul Seixens. "The Spatial Extent of Renewable and Non-Renewable Power Generation: A Review and Meta-Analysis of Power Densities and Their Application in the US." *Energy Policy*, vol. 123, Dec. 2018, pp. 83-91. DOI.org (Crossref), doi:10.1016/j.enpol.2018.09.025.
- 2) "Geothermal Technology Review 2013." *EnergyTech*. US Department of Energy, Sept. 2015. (Online). Accessible: https://www.energy.gov/sites/prod/files/2017/05/f34/geothermal-technology-review-2013_1.pdf. (Accessed March 23, 2020)
- 3) "Statistical Review of World Energy." BP Global, BP Global, 2019. (Online). Accessible: <https://www.bp.com/content/dam/bp/business-sites/en/global/corporate/pdfs/energy-economics/statistical-review-2019-full-report.pdf>. (Accessed March 23, 2020)
- 4) "Fuel Consumption of Conventional Reactor Nuclear Power, Nuclear Power, submersible." (Online). Accessible: <https://www.nuclear-power.net/nuclear-power-plant/nuclear-fuel/fuel-consumption-of-conventional-reactor/>. (Accessed March 23, 2020)
- 5) "Tons Of Coal Equivalent To Tons Of Oil Equivalent | Rights Converter." (Online). Accessible: <http://www.kylesconverter.com/energy-work-and-heat/tons-of-coal-equivalent-to-tons-of-oil-equivalent/>. (Accessed March 23, 2020)
- 6) Wang, T. "Capacity Factor for Selected Energy Sources US, 2018." *Statista*, 21 Oct. 2019. (Online). Accessible: <https://www.statista.com/statistics/1036600/capacity-factor-by-selected-energy-source-us-2018/>. (Accessed March 23, 2020)
- 7) "Cubic Feet Of Natural Gas To Tons Of Oil Equivalent | Rights Converter." (Online). Accessible: <http://www.kylesconverter.com/energy-work-and-heat/cubic-feet-of-natural-gas-to-tons-of-oil-equivalent/>. (Accessed March 23, 2020)
- 8) "Cubic Feet To Tons - Metric Conversion." *Metric Conversions*. Wright Hat Ltd., (Online). Accessible: <http://www.metric-conversions.org/volume/cubic-feet-to-tons.htm>. (Accessed March 23, 2020)
- 9) "HydroNet, (Bio, Biomass Measurements and Conversion | Ag Decision Maker, Iowa State University Oct. 2006. (Online). Accessible: <http://www.netnet.iastate.edu/agdm/wholefarm/html2006/98.html>. (Accessed March 23, 2020)
- 10) Publications Office of the European Union. "Critical Metals in the Paris context (the Decarbonisation of the EU Energy Sector) Assessing Rare Metals as Supply Chain Bottlenecks in Low-Carbon Energy Technologies." 30 Oct. 2014. (Online). Accessible: <http://ec.europa.eu/energy/publication-detail/-/publication/5924286c-7653-4046-bd17-887945811760/language-en/format-PDF>. (Accessed March 23, 2020)
- 11) European Commission. "Critical Raw Materials: Internal Market, Industry, Entrepreneurship and SMEs - European Commission, European Commission, 5 July 2016. (Online). Accessible: https://ec.europa.eu/growth/sectors/raw-materials/specific-interest/critical_en. (Accessed March 23, 2020)

Rethink waste

Many of the misconceptions about nuclear waste have been spread by activists who genuinely fear waste as much as they fear cancer. Meanwhile the most reliable alternative to nuclear energy - coal - actually *is causing cancer*, respiratory issues, and *other serious health problems*.

Fear campaigns have led to tight regulation of nuclear power plants and nuclear waste, which means that to see dry fuel casks you have to jump through hoops with security clearance, over-

the-top security checks, supervised visits and so on.

I think we should normalise nuclear waste by putting it in public places that allow people to see it. In the Netherlands, **COVRA** (The Central Organisation For Radioactive Waste) stores all of the country's high-level waste and is also a public museum and art gallery that hosts many exhibitions.



Inside COVRA: the art of preservation

On a panel in Paris **last year**, I called nuclear power plants national monuments, and I believe that they are, because they represent clean air, good jobs, and high-quality lifestyles. I think we should decorate nuclear power stations like the **mural on the Cruas-Meysse cooling tower** in France. We should celebrate what humankind can achieve with clean energy: a high quality of life for everybody, without the negative impacts of burning fossil fuels.

Now I am in my 30s and I have two children. I have hugged dry fuel casks. I understand that each cask represents 4 billion kilowatt-hours of zero-carbon electricity. That's enough to run nearly 1.3 million homes for a year. I tell this to my children. Every day when I wake up, I am grateful to be able to provide my family with a warm, safe home, as I know that billions of people around the world do not yet share this privilege.





don't understand. After a decade of being afraid, I now understand that nuclear energy is essential for the future and that nuclear waste is a positive part of that future.

Realising all of this about waste and then seeing how it is managed and stored marked a turning point for me from being someone who protested nuclear energy to someone who now champions it globally. Knowledge is power, and no longer fearing something I didn't understand has been liberating. I hope it will be for you too. Because the true waste is the amount of time we spend worrying about spent fuel instead of celebrating what this clean, reliable source of energy gives us.

Zion Lights is a reader-supported publication.

To receive new posts and support my work,
consider becoming a free or paid subscriber.

Type your email...	Subscribe
--------------------	-----------

13 Comments



Write a comment...



Andy Whitelock Feb 10  Liked by Zion Lights

This is the first time I have read your work. Your piece was recommended by someone I follow on Twitter. I don't consider myself an environmentalist by today's standard as I don't think our current use of fossil fuels represents an existential threat to mankind. At the same time, I passionately believe we should find alternative energy sources and get away from our over use of disposable plastics because our continued reliance on these things does harm our environment. Reading your article answered several questions I had regarding nuclear energy and also confirmed concerns I have about our

seemingly blind pursuit of wind energy and battery usage without understanding their substantial environmental and other costs. You did a great job with your investigation into nuclear energy and I appreciate what you have taught me. Kudos.

♡ 5 Reply Gift a subscription Collapse



Forse Feb 10 · *edited Feb 10* ♡ Liked by Zion Lights

Hi Zion: Very useful to have such a thorough review of the nuclear waste issue. I'd say from my friends and relatives, most of whom are anti nuclear, that "what do you do with the waste?" is their biggest question. Problem is of course, that I can give them this article and I'm not sure they will even read it, or if read it, believe it. It's a real issue. Still, I'll keep trying to change views one person at a time.

I've written a piece directed at anti Nuke folks who have said they are open to reading and being persuaded. So far they haven't responded! Sigh. (I cover three areas: Waste, Safety, Costs).

I have to keep reminding myself that I too could suffer from similar cognitive dissonance, as the anti nuke brigade — Not even realise I'm in a bubble! That said, I *did* change my mind, as did Zion, from anti to very pro nuclear.

Let's go, New Clear!

And thanks again to Zion Lights for great work. You are doing good for the world!

Peter Forsythe

Hong Kong

♡ 5 Reply Collapse

11 more comments...
